

SECTION **SB**
SEAT BELT

A
B
C
D
E
F
G
SB
I
J
K
L
M
N
O
P

CONTENTS

PRECAUTION	2	SEAT BELT RETRACTOR : Removal and Installation	5
PRECAUTIONS	2	SEAT BELT RETRACTOR : Inspection	5
Precaution for Supplemental Restraint System (SRS) "AIR BAG" and "SEAT BELT PRE-TENSIONER"	2	SEAT BELT BUCKLE	7
Precaution for Battery Service	2	SEAT BELT BUCKLE : Removal and Installation.....	7
Service Procedure Precautions for Models with a Pop-up Roll Bar	2	SEAT BELT BUCKLE : Inspection	8
Precaution for Seat Belt Service	2	REAR SEAT BELT	9
REMOVAL AND INSTALLATION	4	Exploded View	9
FRONT SEAT BELT	4	SEAT BELT RETRACTOR	9
Exploded View	4	SEAT BELT RETRACTOR : Removal and Installation	9
SEAT BELT RETRACTOR	4	SEAT BELT RETRACTOR : Inspection	10
		SEAT BELT BUCKLE	12
		SEAT BELT BUCKLE : Removal and Installation.....	12
		SEAT BELT BUCKLE : Inspection	12

PRECAUTIONS

< PRECAUTION >

PRECAUTION

PRECAUTIONS

Precaution for Supplemental Restraint System (SRS) "AIR BAG" and "SEAT BELT PRE-TENSIONER"

INFOID:000000008460712

The Supplemental Restraint System such as "AIR BAG" and "SEAT BELT PRE-TENSIONER", used along with a front seat belt, helps to reduce the risk or severity of injury to the driver and front passenger for certain types of collision. This system includes seat belt switch inputs and dual stage front air bag modules. The SRS system uses the seat belt switches to determine the front air bag deployment, and may only deploy one front air bag, depending on the severity of a collision and whether the front occupants are belted or unbelted. Information necessary to service the system safely is included in the "SRS AIR BAG" and "SEAT BELT" of this Service Manual.

WARNING:

Always observe the following items for preventing accidental activation.

- To avoid rendering the SRS inoperative, which could increase the risk of personal injury or death in the event of a collision that would result in air bag inflation, all maintenance must be performed by an authorized NISSAN/INFINITI dealer.
- Improper maintenance, including incorrect removal and installation of the SRS, can lead to personal injury caused by unintentional activation of the system. For removal of Spiral Cable and Air Bag Module, see "SRS AIR BAG".
- Never use electrical test equipment on any circuit related to the SRS unless instructed to in this Service Manual. SRS wiring harnesses can be identified by yellow and/or orange harnesses or harness connectors.

PRECAUTIONS WHEN USING POWER TOOLS (AIR OR ELECTRIC) AND HAMMERS

WARNING:

Always observe the following items for preventing accidental activation.

- When working near the Air Bag Diagnosis Sensor Unit or other Air Bag System sensors with the ignition ON or engine running, never use air or electric power tools or strike near the sensor(s) with a hammer. Heavy vibration could activate the sensor(s) and deploy the air bag(s), possibly causing serious injury.
- When using air or electric power tools or hammers, always switch the ignition OFF, disconnect the battery, and wait at least 3 minutes before performing any service.

Precaution for Battery Service

INFOID:000000008460713

Before disconnecting the battery, lower both the driver and passenger windows. This will prevent any interference between the window edge and the vehicle when the door is opened/closed. During normal operation, the window slightly raises and lowers automatically to prevent any window to vehicle interference. The automatic window function will not work with the battery disconnected.

Service Procedure Precautions for Models with a Pop-up Roll Bar

INFOID:000000008460714

WARNING:

Always observe the following items for preventing accidental activation.

- Risk of passenger injury or death may increase if the pop-up roll bar does not deploy during a roll over collision. In order to reduce the chance of an incident where the pop-up roll bar is inoperative, all maintenance must be performed by a NISSAN or INFINITI dealer.
- Before removing and installing the pop-up roll bar component parts and harness, always turn the ignition switch OFF, disconnect the battery negative terminal, and wait for 3 minutes or more. (The purpose of this operation is to discharge electricity that is accumulated in the auxiliary power supply circuit in the air bag diagnosis sensor unit.)
- When repairing, removing, and installing a pop-up roll bar, always refer to SRS AIR BAG and SRS AIR BAG CONTROL warnings in the Service Manual.

Precaution for Seat Belt Service

INFOID:000000008460715

CAUTION:

PRECAUTIONS

< PRECAUTION >

- Before removing the front seat belt pre-tensioner assembly, turn the ignition switch off, disconnect both battery cables and wait at least 3 minutes. A
- Never use electrical test equipment for front seat belt pre-tensioner connector.
- After replacing or reinstalling front seat belt pre-tensioner assembly, or reconnecting front seat belt pre-tensioner connector, check the system function. Refer to [SRC-13, "Description"](#). B
- Never use disassembled buckle or seat belt assembly.
- Replace anchor bolts if they are deformed or worn out.
- Never oil tongue and buckle.
- If any component of seat belt assembly is questionable, never repair. Replace the entire seat belt assembly. C
- If webbing is cut, frayed or damaged, replace seat belt assembly.
- When replacing seat belt assembly, use a genuine NISSAN seat belt assembly. D

AFTER A COLLISION

WARNING:

Inspect all seat belt assemblies including retractors and attached hardware after any collision. NISSAN/INFINITI recommends that all seat belt assemblies in use during a collision be replaced unless the collision was minor and the belts show no damage and continue to operate properly. Failure to do so could result in serious personal injury in an accident. Seat belt assemblies not in use during a collision should also be replaced if either damage or improper operation is noted. Seat belt pre-tensioners should be replaced even if the seat belts are not in use during a frontal collision in which the air bags are deployed. E

Replace any seat belt assembly (including anchor bolts) if:

- The seat belt is in use at the time of a collision (except for minor collisions and the belts, retractors and buckles show no damage and continue to operate properly). F
- The seat belt is damaged in an accident (i.e. torn webbing, bent retractor or guide). G
- The seat belt attaching point is damaged in an accident. Inspect the seat belt attaching area for damage or distortion and repair as necessary before installing a new seat belt assembly. SB
- Anchor bolts are deformed or worn out.
- The front seat belt pre-tensioner must be replaced even if the seat belts are not in use during the collision in which the air bags are deployed. I

A
B
C
D
E
F
G
SB
I
J
K
L
M
N
O
P

FRONT SEAT BELT

< REMOVAL AND INSTALLATION >

REMOVAL AND INSTALLATION

FRONT SEAT BELT

Exploded View

INFOID:000000008460716

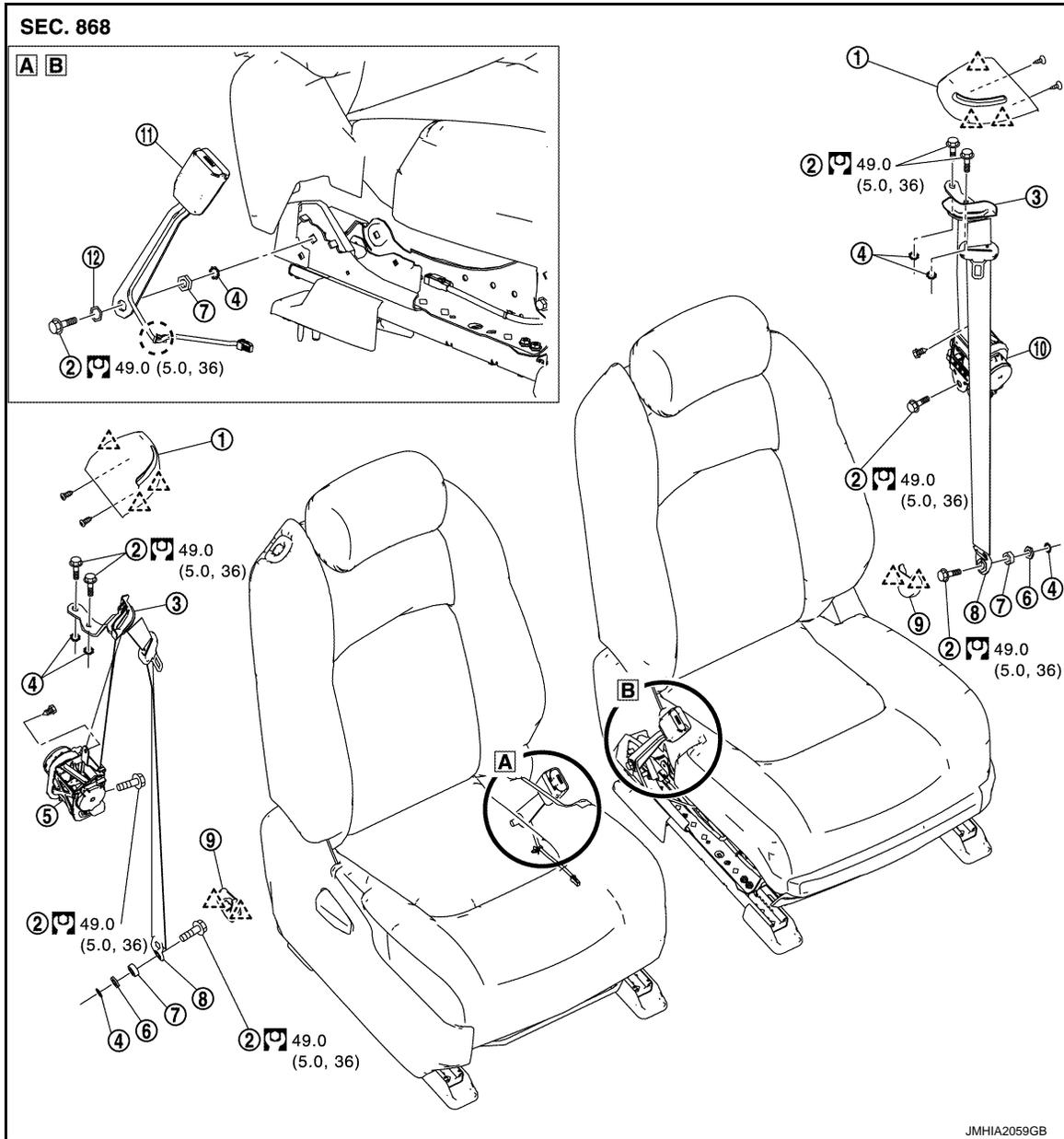

- | | | |
|--|---|-----------------------|
| 1. Front seat belt finisher | 2. Anchor bolt | 3. Shoulder bracket |
| 4. Retaining washer | 5. Seat belt pre-tensioner retractor RH | 6. Spring washer |
| 7. Spacer | 8. Outer anchor | 9. Outer anchor cover |
| 10. Seat belt pre-tensioner retractor LH | 11. Seat belt buckle | 12. Wave washer |

⊙ : Clip

△ : Pawl

[Torque Symbol] : N-m (kg-m, in-lb)

[Torque Symbol] : N-m (kg-m, ft-lb)

SEAT BELT RETRACTOR

FRONT SEAT BELT

< REMOVAL AND INSTALLATION >

SEAT BELT RETRACTOR : Removal and Installation

INFOID:000000008460717

REMOVAL

WARNING:

Before servicing, turn ignition switch OFF, disconnect battery negative terminal and wait 3 minutes or more.

1. Remove outer anchor.
 - a. Pull outer anchor cover in direction indicated by arrow as shown in the figure. Remove outer anchor cover.

 : Pawl

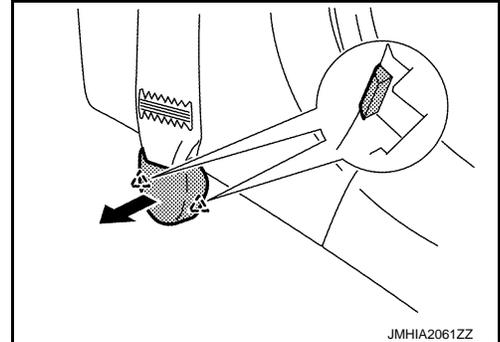

- b. Remove outer anchor mounting anchor bolt.
2. Remove shoulder bracket.
 - a. Remove kicking plate inner. Refer to [INT-19, "KICKING PLATE INNER : Removal and Installation"](#).
 - b. Remove rear side finisher and front seat belt finisher. Refer to [INT-22, "REAR SIDE FINISHER : Removal and Installation"](#).
 - c. Remove shoulder bracket mounting anchor bolts.
3. Remove seat belt pre-tensioner retractor.
 - a. Disconnect seat belt pre-tensioner harness connector.

CAUTION:

- For installing/removing seat belt pre-tensioner connector, insert thin screwdriver wrapped in tape into notch, lift lock and remove connector.
- Install connector with lock raised, and push lock into connector.
- After installing the connector, check that the lock is pushed securely into it.

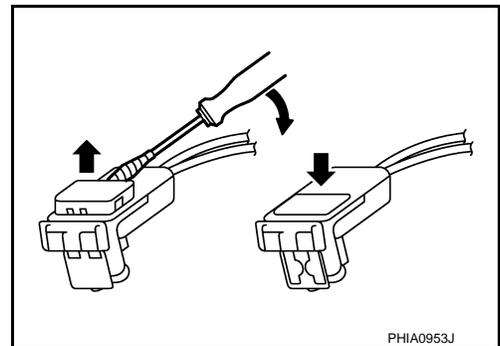

- b. Remove seat belt pre-tensioner retractor mounting anchor bolt and screw.

CAUTION:

Never place pre-tensioner seat belt in an area where the temperature reaches 80°C or more.

INSTALLATION

Install in the reverse order of removal.

SEAT BELT RETRACTOR : Inspection

INFOID:000000008460718

AFTER A COLLISION

WARNING:

Inspect all seat belt assemblies including retractors and attached hardware after any collision. NISSAN/INFINITI recommends that all seat belt assemblies in use during a collision be replaced unless the collision was minor and the belts show no damage and continue to operate properly. Failure to do so could result in serious personal injury in an accident. Seat belt assemblies not in use during a collision should also be replaced if either damage or improper operation is noted. Seat belt pre-tensioners should be replaced even if the seat belts were not in use during a frontal collision in which the air bags were deployed.

FRONT SEAT BELT

< REMOVAL AND INSTALLATION >

Replace any seat belt assembly (including anchor bolts) if:

- The seat belt is in use at the time of a collision (except for minor collisions and the belts, retractors and buckles show no damage and continue to operate properly).
- The seat belt is damaged in an accident (i.e. torn webbing, bent retractor or guide, etc.).
- The seat belt attaching point is damaged in an accident. Inspect the seat belt attaching area for damage or distortion and repair if necessary before installing a new seat belt assembly.
- Anchor bolts are deformed or worn out.
- The seat belt pre-tensioners must be replaced even if the seat belts were not in use during the collision in which the air bags were deployed.

PRELIMINARY CHECKS

1. Check the seat belt warning lamp for proper operation as per the following:
 - a. Turn ignition switch ON. The seat belt warning lamp should illuminate.
 - b. Fasten driver seat belt. The seat belt warning lamp should turn OFF.
2. If the air bag warning lamp is blinking, perform self-diagnosis with CONSULT and air bag warning lamp. Refer to [SRC-13, "Description"](#).
3. Check that the seat belt retractor, seat belt anchor and buckle bolts are tightened firmly.
4. Check the shoulder seat belt guide and shoulder belt height adjuster for front seats. Check that guide swivels freely and that webbing lays flat and does not bind in guide. Check that height adjuster operates properly and holds securely.
5. Check retractor operation:
 - a. Fully extend the seat belt webbing and check for twists, tears and other damage.
 - b. Allow the seat belt to retract. Check that webbing returns smoothly and completely into the retractor. If the seat belt does not return smoothly, wipe the inside of the loops with a clean paper cloth. Dirt build-up in the loops of the upper anchors can cause the seat belts to retract slowly.
 - c. Fasten the seat belt. Check that seat belt returns smoothly and completely to the retractor. If the webbing does not return smoothly, the cause may be an accumulation of dust or dirt. Use the "SEAT BELT TAPE SET" and perform the following steps.

Inspect the front seat belt through-anchor

1. Pull the seat belt out to a length of 500 mm (19.685 in) or more.
 2. Fix the seat belt at the center pillar webbing opening with a clip or other device.
 3. Pass a thin wire through the through-anchor webbing opening. Hold both ends of the wire and pull it tightly while moving it up and down several times along the webbing opening surface to remove dirt stuck there.
 4. Any dirt that cannot be removed with the wire can be removed by cleaning the opening with a clean cloth.
 5. Apply tape at the point where the webbing contacts the through-anchor webbing opening.

NOTE:
Apply the tape so that there is no slack or wrinkling.
 6. Remove the clip fixing the seat belt and check that the webbing returns smoothly.
6. Repeat steps above if necessary to check the other seat belts.

SEAT BELT RETRACTOR ON-VEHICLE CHECK

Emergency Locking Retractors (ELR) and Automatic Locking Retractors (ALR)

NOTE:

All seat belt retractors are Emergency Locking Retractors (ELR) type. In an emergency (sudden stop) the retractor locks and prevent the webbing from extending any further. All 3-point type seat belt retractors except the driver seat belt also have an Automatic Locking Retractors (ALR) mode. The ALR mode (also called child restraint mode) is used when installing child seats. The ALR mode is activated when the seat belt is fully extended. When the webbing is then retracted partially, the ALR mode automatically locks the seat belt in a specific position so the webbing cannot be extended any further. To cancel the ALR mode, allow the seat belt to fully wind back into the retractor.

Check the seat belt retractors with the following test(s) to determine if a retractor assembly is operating properly.

ELR Function Stationary Check

FRONT SEAT BELT

< REMOVAL AND INSTALLATION >

Grasp the shoulder webbing and pull forward quickly. The retractor should lock and prevent the belt from extending further.

ALR Function Stationary Check

1. Pull out the entire length of the seat belt from the retractor until a click is heard.
2. Retract the webbing partially. A clicking noise should be heard as the webbing retracts indicating that the retractor is in the Automatic Locking Retractors (ALR) mode.
3. Grasp the seat belt and try to pull out the retractor. The webbing must lock and not extend any further. If it does not operate normally, replace the retractor assembly.
4. Allow the entire length of the webbing to retract to cancel the automatic locking mode.

ELR Function Moving Check

WARNING:

Perform the following test in a safe, open area clear of other vehicles and obstructions (for example, a large, empty parking lot). Road surface must be paved and dry. Never perform the following test on wet or gravel roads or on public streets and highways. This could result in an accident and serious personal injury. The driver and passenger must be prepared to brace themselves in the event that the retractor does not lock.

1. Fasten driver seat belt. Buckle a passenger into the seat for the belt that is to be tested.
2. Proceed to the designated safe area.
3. Drive the vehicle at approximately 16 km/h (10 MPH). Notify any passengers of a sudden stop and the driver and passenger must be prepared to brace themselves in the event that the retractor does not lock. Apply brakes firmly and make a very hard stop.

During stopping, seat belts should lock and not be extended. If the seat belt retractor assembly does not lock, perform the retractor off-vehicle check.

SEAT BELT RETRACTOR OFF-VEHICLE CHECK

1. Remove the seat belt retractor.
Remove the front seat belt assembly. Refer to [SB-5, "SEAT BELT RETRACTOR : Removal and Installation"](#).
2. Slowly pull out webbing while tilting the retractor assembly forward from the mounted position without twisting the retractor assembly as shown in the illustration.
 - The webbing can be pulled out when the angle (A) is 15 degrees or less.
 - The webbing cannot be pulled out when the angle (B) is 35 degrees or more.

A and B : Tilting angles

← : Vehicle front

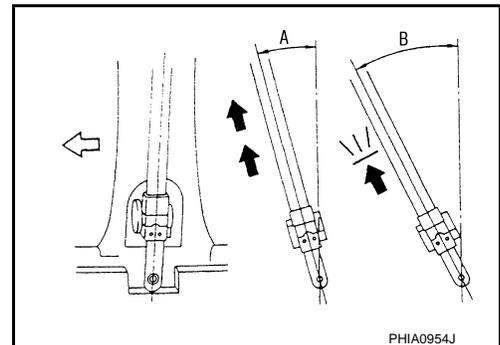

3. Replace the seat belt assembly if it does not operate normally.

SEAT BELT BUCKLE

SEAT BELT BUCKLE : Removal and Installation

INFOID:000000008460719

REMOVAL

1. Remove front seat from the vehicle.
 - Driver seat: Refer to [SE-28, "Removal and Installation"](#).
 - Passenger seat: Refer to [SE-39, "Removal and Installation"](#).

CAUTION:

When removing and installing, use shop cloths to protect parts from damage.

FRONT SEAT BELT

< REMOVAL AND INSTALLATION >

2. Disconnect harness connector (A), and then disconnect harness fixing clip (B).

 : Clip

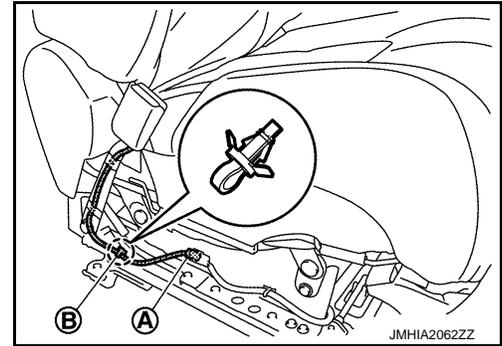

3. Remove seat belt buckle mounting anchor bolt, and then remove the seat belt buckle.

INSTALLATION

Install in the reverse order of removal.

SEAT BELT BUCKLE : Inspection

INFOID:000000008460720

AFTER A COLLISION

WARNING:

Inspect all seat belt assemblies including retractors and attached hardware after any collision. NISSAN/INFINITI recommends that all seat belt assemblies in use during a collision be replaced unless the collision was minor and the belts show no damage and continue to operate properly. Failure to do so could result in serious personal injury in an accident. Seat belt assemblies not in use during a collision should also be replaced if either damage or improper operation is noted. Seat belt pre-tensioners should be replaced even if the seat belts were not in use during a frontal collision in which the air bags were deployed.

Replace any seat belt assembly (including anchor bolts) if:

- The seat belt is in use at the time of a collision (except for minor collisions and the belts, retractors and buckles show no damage and continue to operate properly).
- The seat belt is damaged in an accident (i.e. torn webbing, bent retractor or guide, etc.).
- The seat belt attaching point is damaged in an accident. Inspect the seat belt attaching area for damage or distortion and repair if necessary before installing a new seat belt assembly.
- Anchor bolts are deformed or worn out.
- The seat belt pre-tensioner must be replaced even if the seat belts were not in use during the collision in which the air bags were deployed.

PRELIMINARY CHECKS

1. Check the seat belt warning lamp for proper operation as follows:
 - a. Turn ignition switch ON. The seat belt warning lamp should illuminate.
 - b. Fasten driver seat belt. The seat belt warning lamp should turn OFF.
2. If the air bag warning lamp is blinking, conduct self-diagnosis using CONSULT and air bag warning lamp. Refer to [SRC-13, "Description"](#).
3. Check that the seat belt retractor, seat belt anchor and buckle bolts are tightened firmly.
4. Repeat steps above if necessary to check the other seat belts.

REAR SEAT BELT

< REMOVAL AND INSTALLATION >

REAR SEAT BELT

Exploded View

INFOID:000000008460721

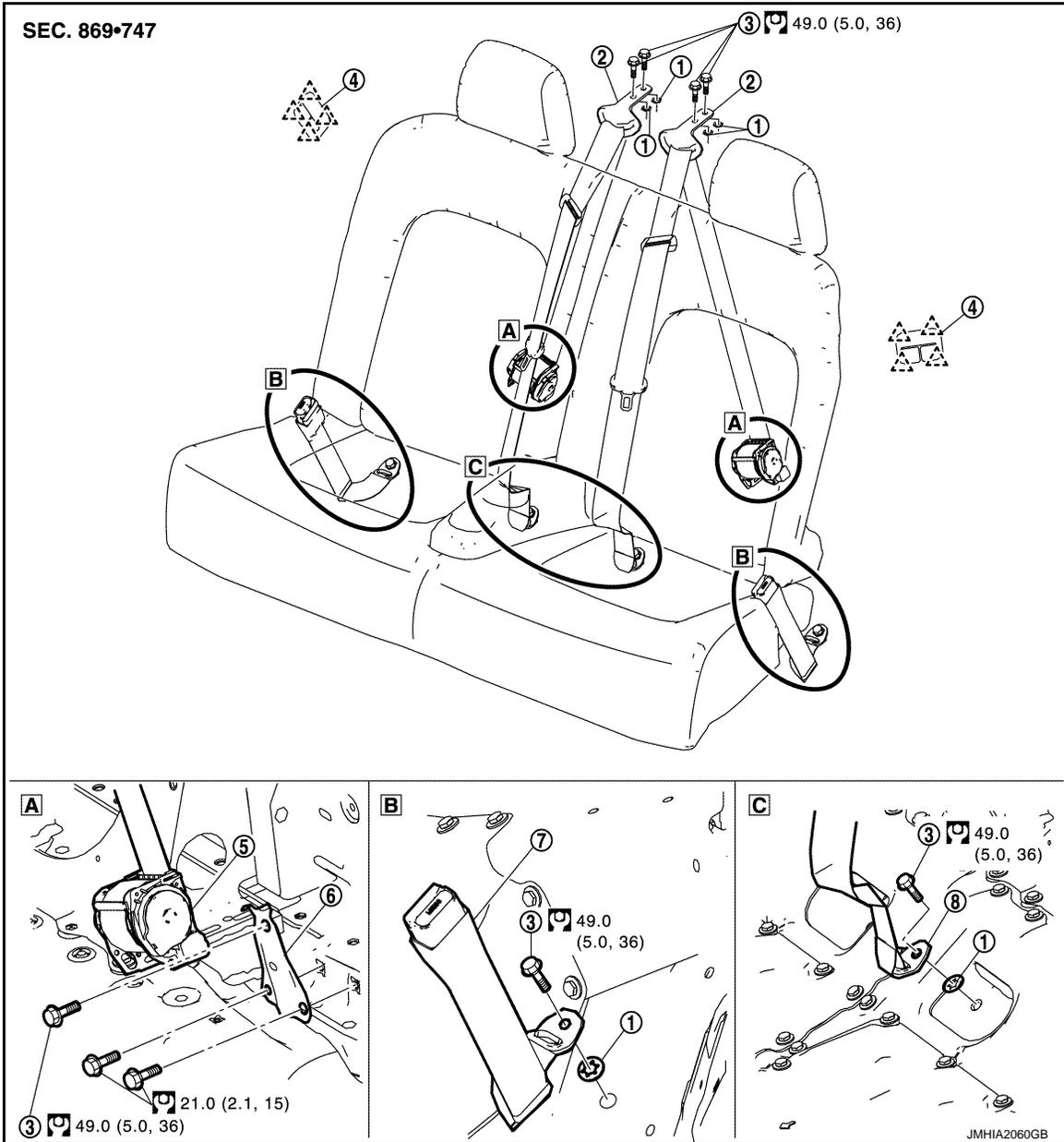

- | | | |
|----------------------------|------------------------|----------------------|
| 1. Retaining washer | 2. Shoulder bracket | 3. Anchor bolt |
| 4. Rear seat belt finisher | 5. Seat belt retractor | 6. Seat belt bracket |
| 7. Seat belt buckle | 8. Outer anchor | |

: Pawl

: N-m (kg-m, ft-lb)

SEAT BELT RETRACTOR

SEAT BELT RETRACTOR : Removal and Installation

INFOID:000000008460722

REMOVAL

1. Remove outer anchor.

A
B
C
D
E
F
G
SB
I
J
K
L
M
N
O
P

REAR SEAT BELT

< REMOVAL AND INSTALLATION >

- a. Remove rear seat cushion. Refer to [SE-50, "SEAT CUSHION : Removal and Installation"](#).
- b. Remove outer anchor mounting anchor bolt.
2. Remove shoulder bracket.
- a. Remove seat belt finisher from seatback.
Lift up lower of rear seat belt finisher. Disengage lower pawls.
Pull rear seat belt finisher toward rear seat lower. Disengage upper pawls.

 : Pawl

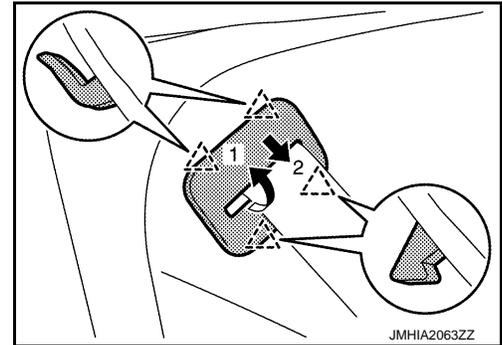

- b. Remove rear seatback. Refer to [SE-49, "SEATBACK : Removal and Installation"](#).
- c. Remove guard frame protector assembly. Refer to [INT-29, "GUARD FRAME PROTECTOR ASSEMBLY : Removal and Installation"](#).
- d. Remove rear parcel shelf front finisher. Refer to [INT-30, "REAR PARCEL SHELF FRONT FINISHER : Removal and Installation"](#).
- e. Remove shoulder bracket mounting anchor bolts.
3. Remove rear seat belt retractor.
- a. Remove rear side finisher and front seat belt finisher. Refer to [INT-22, "REAR SIDE FINISHER : Removal and Installation"](#).
- b. Remove LATCH system for children bracket (LH and RH). Refer to [SE-54, "Removal and Installation"](#).
- c. Remove rear seatback side support assembly (LH and RH) mounting bolts and nuts, and then remove rear seatback side support assembly. Refer to [SE-48, "Exploded View"](#).
- d. Remove rear floor plate assembly (LH and RH) mounting bolts and nut, and then remove rear floor plate assembly. Refer to [SE-48, "Exploded View"](#).
- e. Remove wheel house member support assembly (LH and RH) mounting bolts and nut, and then remove wheel house number support assembly. Refer to [SE-48, "Exploded View"](#).
- f. Remove rear seat belt retractor mounting anchor bolt.
4. Remove seat belt bracket mounting bolts and harness fixing clip, and then remove seat belt bracket.

INSTALLATION

Install in the reverse order of removal.

SEAT BELT RETRACTOR : Inspection

INFOID:000000008460723

AFTER A COLLISION

WARNING:

Inspect all seat belt assemblies including retractors and attached hardware after any collision. NISSAN/INFINITI recommends that all seat belt assemblies in use during a collision be replaced unless the collision was minor and the belts show no damage and continue to operate properly. Failure to do so could result in serious personal injury in an accident. Seat belt assemblies not in use during a collision should also be replaced if either damage or improper operation is noted. Seat belt pretensioners should be replaced even if the seat belts were not in use during a frontal collision in which the air bags were deployed.

Replace any seat belt assembly (including anchor bolts) if:

- The seat belt is in use at the time of a collision (except for minor collisions and the belts, retractors and buckles show no damage and continue to operate properly).
- The seat belt is damaged in an accident (i.e. torn webbing, bent retractor or guide, etc.).
- The seat belt attaching point is damaged in an accident. Inspect the seat belt attaching area for damage or distortion and repair if necessary before installing a new seat belt assembly.
- Anchor bolts were deformed or worn out.

PRELIMINARY CHECKS

REAR SEAT BELT

< REMOVAL AND INSTALLATION >

1. Check that the seat belt retractor, seat belt anchor and buckle bolts are tightened firmly.
2. Check the shoulder seat belt guide and shoulder belt height adjuster for front seats. Check that guide swivels freely and that webbing lays flat and does not bind in guide. Check that height adjuster operates properly and holds securely.
3. Check retractor operation:
 - a. Fully extend the seat belt webbing and check for twists, tears and other damage.
 - b. Allow the seat belt to retract. Ensure that webbing returns smoothly and completely into the retractor. If the seat belt does not return smoothly, wipe the inside of the loops with a clean paper cloth. Dirt build-up in the loops of the upper anchors can cause the seat belts to retract slowly.
 - c. Fasten the seat belt. Check that seat belt returns smoothly and completely to the retractor. If the webbing does not return smoothly, the cause may be an accumulation of dust or dirt. Use the "SEAT BELT TAPE SET" and perform the following steps.

Inspect the front seat belt through-anchor

1. Pull the seat belt out to a length of 500 mm (19.685 in) or more.
 2. Fix the seat belt at the center pillar webbing opening with a clip or other device.
 3. Pass a thin wire through the through-anchor webbing opening. Hold both ends of the wire and pull it tightly while moving it up and down several times along the webbing opening surface to remove dirt stuck there.
 4. Any dirt that cannot be removed with the wire can be removed by cleaning the opening with a clean cloth.
 5. Apply tape at the point where the webbing contacts the through-anchor webbing opening.

NOTE:
Apply the tape so that there is no slack or wrinkling.
 6. Remove the clip fixing the seat belt and check that the webbing returns smoothly.
4. Repeat the steps above as necessary to check the other seat belts.

SEAT BELT RETRACTOR ON-VEHICLE CHECK

Emergency Locking Retractors (ELR) and Automatic Locking Retractors (ALR)

NOTE:

All seat belt retractors are Emergency Locking Retractors (ELR) type. In an emergency (sudden stop) the retractor will lock and prevent the webbing from extending any further. All 3-point type seat belt retractors except the driver seat belt also have an Automatic Locking Retractors (ALR) mode. The ALR mode (also called child restraint mode) is used when installing child seats. The ALR mode is activated when the seat belt is fully extended. When the webbing is then retracted partially, the ALR mode automatically locks the seat belt in a specific position so the webbing cannot be extended any further. To cancel the ALR mode, allow the seat belt to fully wind back into the retractor.

Check the seat belt retractors with the following test(s) to determine if a retractor assembly is operating properly.

ELR Function Stationary Check

Grasp the shoulder webbing and pull forward quickly. The retractor should lock and prevent the belt from extending further.

ALR Function Stationary Check

1. Pull out the entire length of the seat belt from the retractor until a click is heard.
2. Retract the webbing partially. A clicking noise should be heard as the webbing retracts indicating that the retractor is in the Automatic Locking Retractors (ALR) mode.
3. Grasp the seat belt and try to pull out the retractor. The webbing must lock and not extend any further. If it does not operate normally, replace the retractor assembly.
4. Allow the entire length of the webbing to retract to cancel the automatic locking mode.

ELR Function Moving Check

WARNING:

Perform the following test in a safe, open area clear of other vehicles and obstructions (for example, a large, empty parking lot). Road surface must be paved and dry. Never perform the following test on wet or gravel roads or on public streets and highways. This could result in an accident and serious personal injury. The driver and passenger must be prepared to brace themselves in the event that the retractor does not lock.

REAR SEAT BELT

< REMOVAL AND INSTALLATION >

1. Fasten driver seat belt. Buckle a passenger into the seat for the belt that is to be tested.
2. Proceed to the designated safe area.
3. Drive the vehicle at approximately 16 km/h (10 MPH). Notify any passengers of a sudden stop and the driver and passenger must be prepared to brace themselves in the event that the retractor does not lock. Apply brakes firmly and make a very hard stop.

During stopping, seat belts should lock and not be extended. If the seat belt retractor assembly does not lock, perform the retractor off-vehicle check.

SEAT BELT RETRACTOR OFF-VEHICLE CHECK

1. Remove the seat belt retractor.
Remove the rear seat belt assembly. Refer to [SB-9, "SEAT BELT RETRACTOR : Removal and Installation"](#).
2. Slowly pull out webbing while tilting the retractor assembly forward from the mounted position without twisting the retractor assembly as shown in the illustration.
 - The webbing can be pulled out when the angle (A) is 15 degrees or less.
 - The webbing cannot be pulled out when the angle (B) is 35 degrees or more.

A and B : Tilting angles

← : Vehicle front

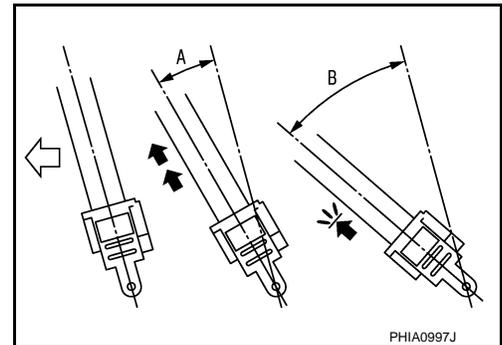

3. Replace the seat belt assembly if it does not operate normally.

SEAT BELT BUCKLE

SEAT BELT BUCKLE : Removal and Installation

INFOID:000000008460724

REMOVAL

1. Remove rear seat cushion. Refer to [SE-50, "SEAT CUSHION : Removal and Installation"](#).
2. Remove seat belt buckle mounting anchor bolt, and then remove seat belt buckle.

INSTALLATION

Install in the reverse order of removal.

SEAT BELT BUCKLE : Inspection

INFOID:000000008460725

AFTER A COLLISION

WARNING:

Inspect all seat belt assemblies including retractors and attached hardware after any collision. NISSAN/INFINITI recommends that all seat belt assemblies in use during a collision be replaced unless the collision was minor and the belts show no damage and continue to operate properly. Failure to do so could result in serious personal injury in an accident. Seat belt assemblies not in use during a collision should also be replaced if either damage or improper operation is noted. Seat belt pretensioners should be replaced even if the seat belts are not in use during a frontal collision in which the air bags were deployed.

Replace any seat belt assembly (including anchor bolts) if:

- The seat belt is in use at the time of a collision (except for minor collisions and the belts, retractors and buckles show no damage and continue to operate properly).
- The seat belt is damaged in an accident. (i.e. torn webbing, bent retractor or guide, etc.)
- The seat belt attaching point is damaged in an accident. Inspect the seat belt attaching area for damage or distortion and repair if necessary before installing a new seat belt assembly.
- Anchor bolts are deformed or worn out.

PRELIMINARY CHECKS

REAR SEAT BELT

< REMOVAL AND INSTALLATION >

1. Check that the seat belt retractor, seat belt anchor and buckle bolts are tightened firmly.
2. Repeat the step above if necessary to check the other seat belts.

A

B

C

D

E

F

G

SB

I

J

K

L

M

N

O

P